



**APPROVALS**



 **ENGINEERING CODE**  
959AA51

 **APPROVED REFRIGERANT**  
R-404A

 **POWER SUPPLY**  
220-240 V 50 Hz

 **STANDARD CONDITIONS**  
EN12900

 **APPLICATION**  
LBP

 **COOLING CAPACITY**  
347 W (LBP)

 **EFFICIENCY**  
1 W/W (LBP)

 **MOTOR TYPE**  
CSIR

 **STARTING TORQUE**  
HST

**DATA**

**General Data**

Type	Hermetic reciprocating
Technology Type	On-Off
Displacement	12.11 cm <sup>3</sup>
Compressor Cooling	Fan/NotControlled/220
Fan Air Flow	520 m <sup>3</sup> /h
Expansion Device	Capillary Tube or Expansion Valve
Horse Power	1/2 hp
Max Condensing Pressure Operating	24.71 bar
Max Condensing Pressure Peak	27.71 bar
Power Supply	220-240 V 50 Hz
Evaporating Temperature Range	-40 °C to -10 °C

**Electrical Data**

Motor type	CSIR
Starting Torque	HST
Start Winding Resistance	27.95 Ω at 25° C
Run Winding Resistance	5.11 Ω at 25° C

## Mechanical Data

Maximum Recommended Refrigerant Charge	350 g
Oil Charge	350 ml
Oil Type Configuration	ESTER
Oil Type Viscosity	ISO22
Pressurization	Dry air charge
Weight	11.55 Kg
Free Internal Volume	2.1 L

## Electrical Components

	Description
Start Capacitor	72-88 Uf / 330 V
Starting Device	Relay   MTRP-0012*
Motor Protection	T0634/G6

## External Characteristics

Base Plate	European	
Tray Holder	No	
Height	206 mm	
Connector	Internal Diameter	Shape
Suction	8.1 mm	Slanted 42°/Copper
Discharge	6.1 mm	Straight/Copper
Process	6.1 mm	Slanted 42°/Copper

## PERFORMANCE

## Rated Points

Condensing Temperature	Evaporating Temperature	Cooling Capacity	Power Consumption	Gas Flow Rate	Efficiency
40.00°C	-35.00°C	347 W	348 W	9.31 kg/h	1 W/W

Test Condition: EN12900LBP, Fan/NotControlled/220, Return Gas 20°C, Evaporation -35.00°C, Condensing 40.00°C, Ambient 35°C, Liquid 40°C, Subcooling 0K. Data are an indication of performance based simulation.

## Performance Curve Data

### Condensing Temperature 35°C

Evaporating Temperature °C	Cooling Capacity W	Power W	Gas Flow Rate kg/h	Efficiency W/W
-40	283	302	7.18	0.93
-35	370	348	9.44	1.06
-30	478	392	12.26	1.22
-25	609	437	15.69	1.39
-20	763	482	19.79	1.58
-15	943	529	24.62	1.78
-10	1147	577	30.23	1.99

Test Condition: EN12900LBP, Fan/NotControlled/220, Return Gas 20°C, Ambient 35°C, Subcooling OK. Data are an indication of performance based simulation.

### Condensing Temperature 45°C

Evaporating Temperature °C	Cooling Capacity W	Power W	Gas Flow Rate kg/h	Efficiency W/W
-35	303	356	8.77	0.85
-30	395	409	11.48	0.97
-25	506	463	14.79	1.09
-20	636	520	18.75	1.22
-15	787	579	23.41	1.36
-10	960	643	28.83	1.49

Test Condition: EN12900LBP, Fan/NotControlled/220, Return Gas 20°C, Ambient 35°C, Subcooling OK. Data are an indication of performance based simulation.

### Condensing Temperature 55°C

Evaporating Temperature °C	Cooling Capacity W	Power W	Gas Flow Rate kg/h	Efficiency W/W
-30	306	423	10.44	0.72
-25	396	484	13.62	0.82
-20	502	549	17.42	0.91
-15	625	619	21.90	1.01
-10	766	694	27.13	1.1

Test Condition: EN12900LBP, Fan/NotControlled/220, Return Gas 20°C, Ambient 35°C, Subcooling OK. Data are an indication of performance based simulation.

## Operating Envelope



## External Dimensions

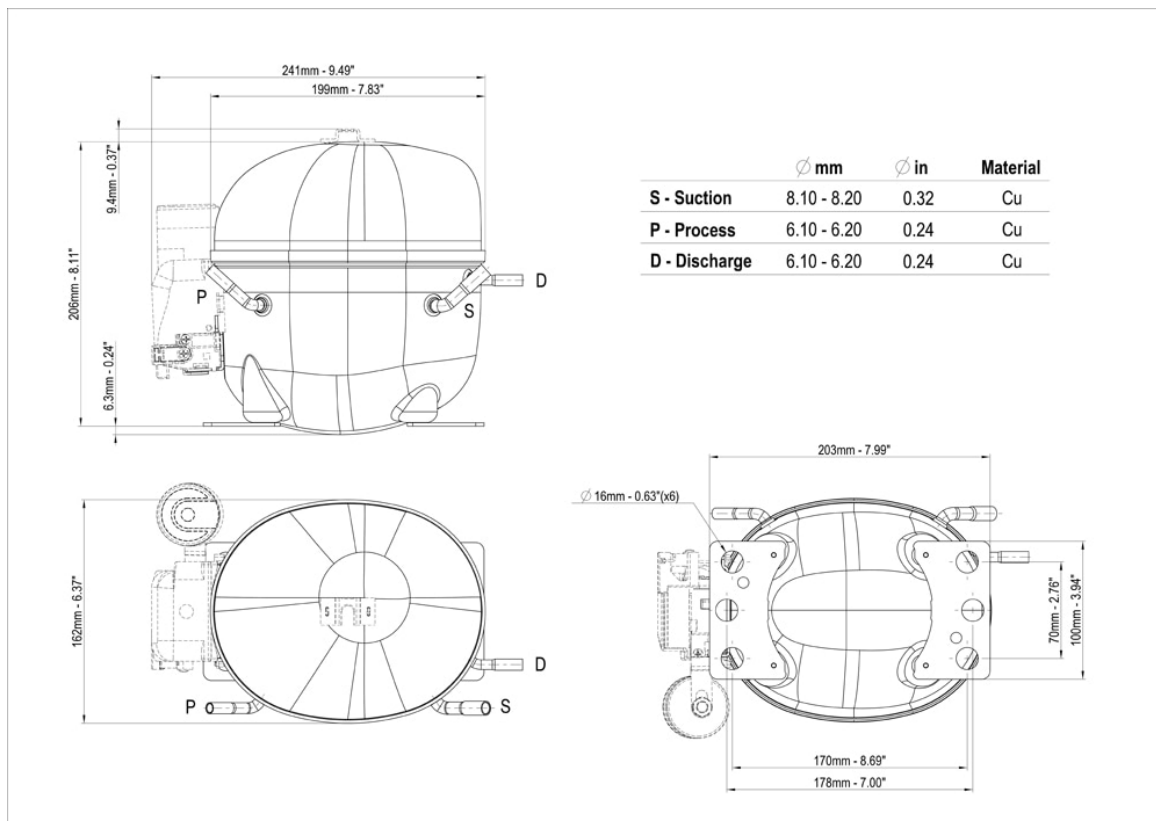

## Wiring Diagram

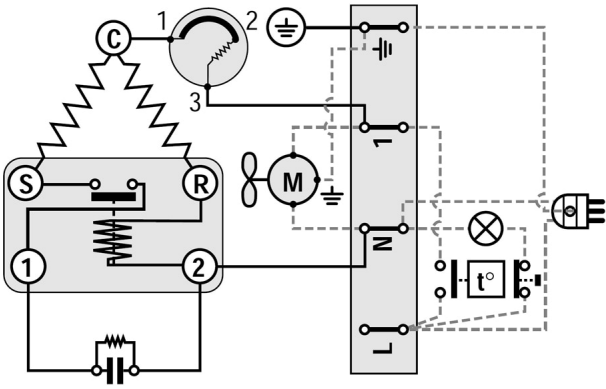

## Assembly Instructions

