



Compressor
Voltage Code : FZ

FH5527E

Air Conditioning & Heating (CA)

220 - 240V 1~ 50 Hz

R22

AHC5527EFZ

Conditions	Frequency	Nominal Cooling Capacity		Sound Power ISO3745 / ISO 3743-1
		Watts	BTU/h	
EN12900 / R22	50 Hz	5927	20210	70 dBA

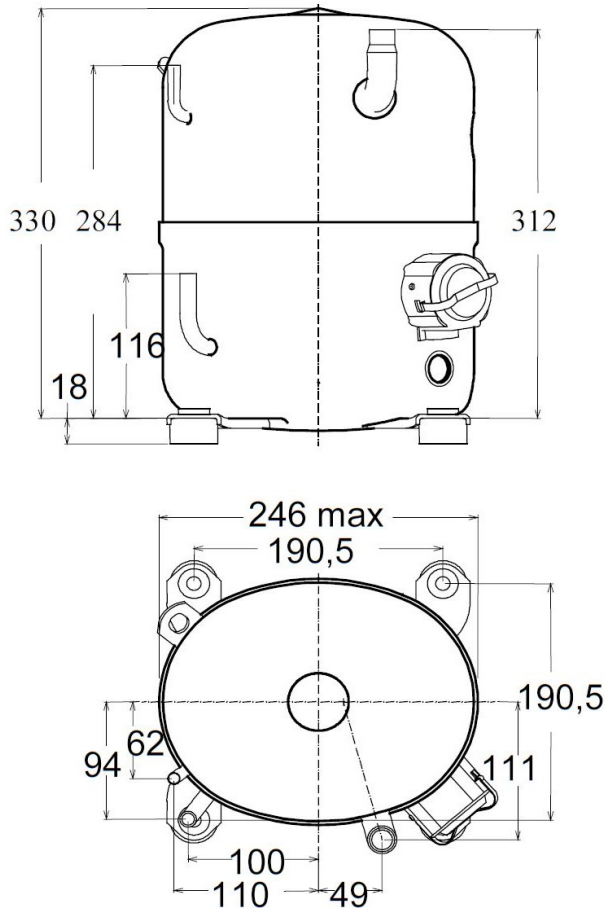

Displacement (cc)	49,1
Net Weight (Kg)	32.0
Oil Quantity (cc)	1330.0
Oil Type	Mineral
Expansion Device	Capillary_Tube
Cooling	Fan
Main Winding (Ohm)	1.05
Start Winding (Ohm)	3.21
Current	
RLA (A)	12
MCC (A)	19.5
LRA (A)	60
Electrical Equipment	PTCSCR,CSR,PSC
Overload	Interne
Start Capacitor	88 µF / 330 V
Run Capacitor	35 µF / 400 V
Potential Relay	3ARR3*6AS*
Pick Up	180/195V
Drop Out	60/121V
Optional	RVA4G**
PTC	CTP305C2
Resistance	50 Ohms
Refrigerating connection for OD	
Suction Tube	15.9 (5/8")
Discharge Tube	9.5 (3/8")
Process Tube	6.35 (1/4")

* EN12900 : T°Cond. 50.0°C / T°Evap. 5.0°C / T°Superheat. 10.0°C
T°Subcooling. 0.0K

Certificates :



Note : Tecumseh reserves the right to change information contained in this document without notification.



Tecumseh

FH5527E	Tension FZ : 220 - 240V 1~ 50 Hz
----------------	---

Les performances sont données dans les conditions EN12900 :	Surchauffe :	10.0 K
Condition Dew	Sous refroidissement :	0.0 K
The performance data are in EN12900 conditions :	Superheat :	10.0 K
Dew Condition	Subcooling :	0.0 K

50 Hz R22

N°335UG-F

4 T condensation	5 T évaporation	(°C)	-25	-20	-15	-10	-5	0	5	10	15
40	1 P frigorifique	(Watt)				3553	4485	5650	7049	8680	10546
	2 P absorbée	(W)				1809	1970	2113	2237	2343	2430
	3 I absorbée	(A)				9.18	9.79	10.3	10.8	11.2	11.4
50	1 P frigorifique	(Watt)					3688	4707	5927	7349	8974
	2 P absorbée	(W)					2079	2281	2459	2615	2747
	3 I absorbée	(A)					10.1	10.9	11.6	12.3	12.8
60	1 P frigorifique	(Watt)						3794	4845	6066	7459
	2 P absorbée	(W)						2452	2684	2888	3064
	3 I absorbée	(A)						11.5	12.5	13.4	14.1

© 2021 Tecumseh Products Company
All rights reserved

1 = cooling capacity 2 = power input 3 = current 4 = condensing temperature 5 = evaporating temperature

Nota : Tecumseh se réserve le droit de modifier les informations contenues dans ce document sans préavis.

Note : Tecumseh reserves the right to change information contained in this document without notification.